

Electric Stacker *NE* series

- ◆ Highly maneuverable, lightweight lifts, designed to take the strain out of any lifting job from ground level to over shoulder height.
- ◆ Ideal for use in narrow aisles and confined spaces. Perfect for all applications from pharmaceutical to catering, from packing line to food processing, from warehouse to office, kitchens, laboratories, retail outlets, etc...
- ◆ Quick lift pump provides high efficiency.
- ◆ *Non-marking castor as standard.*
- ◆ *Conforms to EN1757.*



NE4012F



NE4012PB

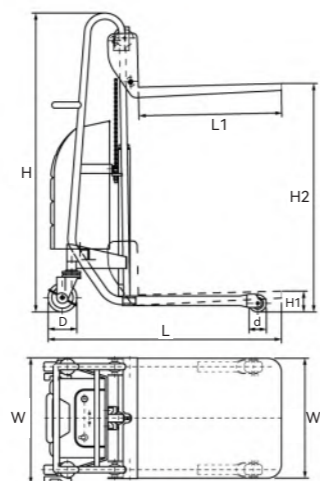

Platform Type

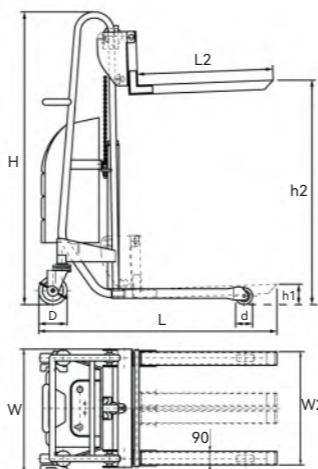

Fork Type

Model		NS2094	NS2010	NS4012
Type		Platform		Adjustable Fork
Capacity	(kg)	400	400	400
Max. Fork Height	H2(mm)	1210	1270	-
Min. Fork Height	H1(mm)	90	150	90
Platform Length	L1(mm)	670	670	-
Platform Width	W1(mm)	590	590	-
Min. Fork Height	h1(mm)	-	-	90
Max. Fork Height	h2(mm)	-	-	1210
Fork Length	L2(mm)	-	-	700
Single Fork Width	(mm)	-	-	90
Fork Width	W2(mm)	-	-	190-572
Front Wheel Dia.	D(mm)	75	75	75
Steering Wheel Dia.	d(mm)	125	125	125
Power Pack Motor	(Kw)	0.8	0.8	0.8
Battery	(V/Ah)	12/70	12/70	12/70
Overall Size	LxWxH(mm)	1190x620x1610	1190x620x1635	1270x620x1610
Net Weight	(kg)	116	118	117

Electric Fork Type Stacker *EJ* Series

- ◆ Low profile forks can lift pallet easily.
- ◆ No-marking castor as standard.
- ◆ Conforms to EN 1757-1.

Manual

- ◆ Ladder as option.

Electric

- ◆ Easier and faster lifting operation.
- ◆ High quality hydraulic motor made in Italy.
- ◆ Service free battery.
- ◆ Option platform available.



Model (Adjustable Fork)		EJ2085A	EJ2120A	EJ4085A	EJ4120A	EJ4150A
Capacity	(kg)	200	200	400	400	400
Max. Fork Height	(mm)	850	1200	850	1200	1500
Min. Fork Height	(mm)	85	85	85	85	85
Fork Length	(mm)	600	600	650	650	650
Adjustable Fork Width	(mm)	215-500	215-500	235-500	235-500	235-500
Load Roller	(mm)	Ø75	Ø75	Ø75	Ø75	Ø75
Steering Wheel	(mm)	Ø125	Ø125	Ø125	Ø125	Ø125
Pump Strokes to Max. Height		19	26	35	50	63
Overall Height	(mm)	1080	1435	1060	1410	1710
Overall Width	(mm)	560	560	590	590	590
Overall Length	(mm)	1020	1020	1100	1100	1100
Chassis Height	(mm)	32.5	32.5	22.5	22.5	22.5
Power Motor	(KW)	0.8	0.8	0.8	0.8	0.8
Battery	(Ah/V)	60/12	60/12	70/12	70/12	70/12
Net Weight	(kg)	93	100	110	121	127
Option Platform		LP10	LP10	LP20	LP20	LP20

Fork Type Stacker *EK* series

- ◆ Low profile forks can lift pallet easily.
- ◆ No-marking castor as standard.
- ◆ Conforms to EN 1757-1.

Electric

- ◆ Easier and faster lifting operation.
- ◆ High quality hydraulic motor made in Italy.
- ◆ Service free battery.
- ◆ Option platform available.



Model		EK2235	EK2250	EK5120	EK5150
Fork				Fixed	
Capacity	(kg)	200	200	500	500
Max. Fork Height	(mm)	2350	2500	1200	1500
Min. Fork Height	(mm)	95	95	95	95
Fork Width	(mm)			850	
Steering Wheel	(mm)	125	125	125	125
Load Roller	(mm)	75	75	75	75
Overall Height	(mm)	1650	1725	1630	1910
Overall Width	(mm)			850	
Battery	(Ah)	12VDC-70Ah	12VDC-70Ah	12VDC-70Ah	12VDC-70Ah
Power Pack	(KW)	12VDC-0.8kW	12VDC-0.8kW	12VDC-0.8kW	12VDC-0.8kW
Ground Clearance	(mm)	23	23	23	23